

**GENERAL FEATURE**

Floating ball / *Boisseau flottant*  
 3 pieces Construction / *Construction 3 pièces*  
 Full bore / *Passage intégral*  
 Soft seat / *Siège souple*  
 Bidirectional  
 TA-LUFT  
 Anti Blow out proof stem.  
 Autoadjustable packing.  
 Anti static device.

**STANDARDS**

Marking : MSS SP25  
 Top flange ISO 5211  
 Testing : API 598, Rate A  
 Design : selon B16-34  
 SW Connections : ASME B16.11  
 BW Connections : ASME B16.5 (ou B16.25)  
 MATERIAL = ASTM and NACE MR0175-0103 (wetted parts)

**OFFICIAL APPROVALS**

FIRE SAFE  
 ISO 15848 RATE B  
 ATEX IM2 / II 2 GD  
 PED Module H  
 SIL 3  
 EN 161/EN 264

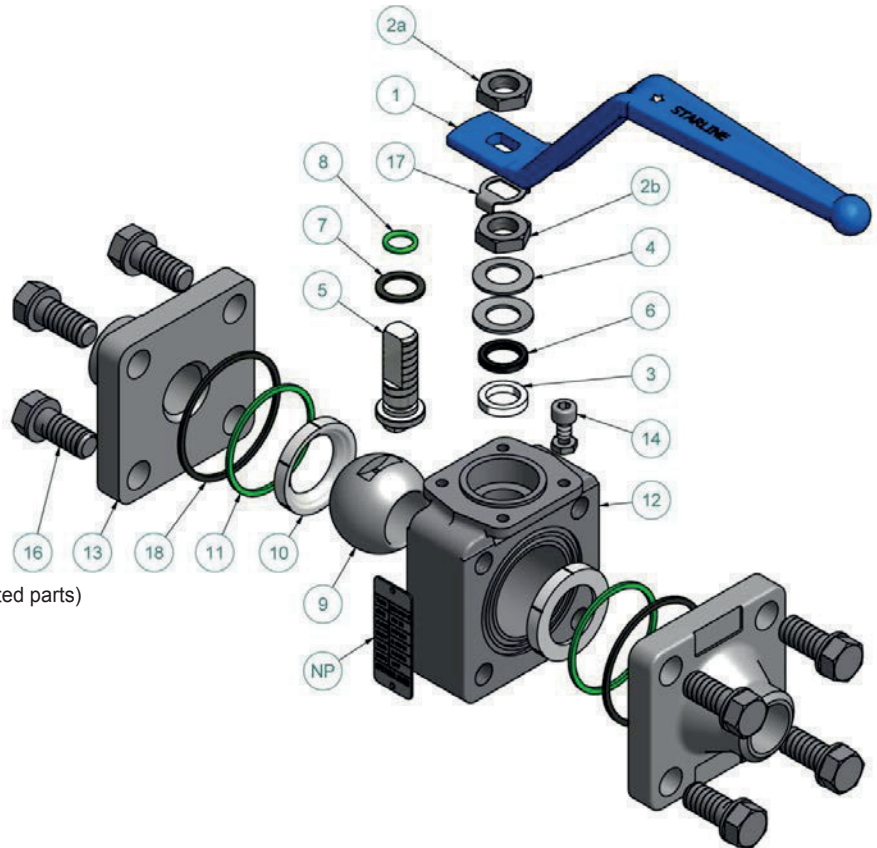

ITEM NO	QTY	PART NAME	NOMENCLATURE	CARBON STEEL MATERIAL 135 SGSG-CL150-800	STAINLESS STEEL MATERIAL 136 SGSG-CL150-800
NP	1	Name plate	Plaque d'identification	AISI 316	AISI 316
1	1	Handle	Levier	Carbon steel + Epoxy coated	Carbon steel + Epoxy coated
2a	2	Handle nut	Ecrou levier	AISI 316	AISI 316
2b					
3	1	Packing ring	Garniture	Graphite	Graphite
4	2	Spring washers	Rondelle ressort	AISI 316 Treated	AISI 316 Treated
5	1	Antistatic stem	Tige antistatique	AISI 316/316L Dual Certified	AISI 316/316L Dual Certified
6	1 <sup>Note 1</sup>	Gland packing	Fouloir	AISI 316	AISI 316
7	1	Thrust washer	Rondelle butée	PTFE	PTFE
8	1	"O" ring stem	Joint torique	Viton	Viton
9	1	Ball	Sphère	AISI 316/316L Dual Certified	AISI 316/316L Dual Certified
10	2	Seats	Sièges	"RPTFE"	"RPTFE"
11	2	1° Body seals	1° Joint de corps	"RPTFE"	"RPTFE"
12	1	Body	Corps	LF2	AISI 316/316L Dual Certified
13	2	End connections	Embout	LF2	AISI 316/316L Dual Certified
14	1	Stop-pin	Butée	AISI 316	AISI 316
16	8	Bolts	Vis	L7 + Zinc Plated	B8
17	1	Stop washer	Rondelle frein	AISI 316	AISI 316
18	2	2° Body seals	2° Joint de corps	Graphite	Graphite

Note 1: Qty 2 for DN 20 - 3/4"

# MASTER STAR N°3 FLOATING BALL VALVE

CLASS 150+800 - DN08+40 FB - 1/4"+1.1/2" FB

RACCORDEMENT A SOUDER

Fig: 135SGS /136SGS

WELDING ENDS

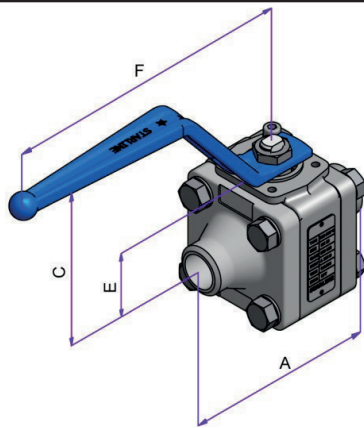

**BW**

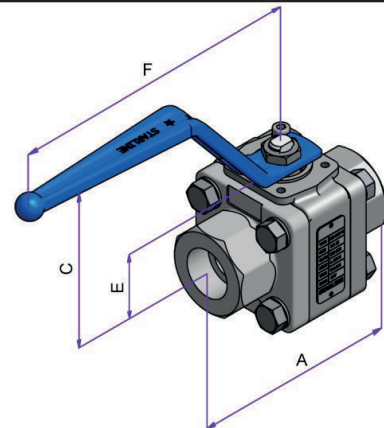

**SW**

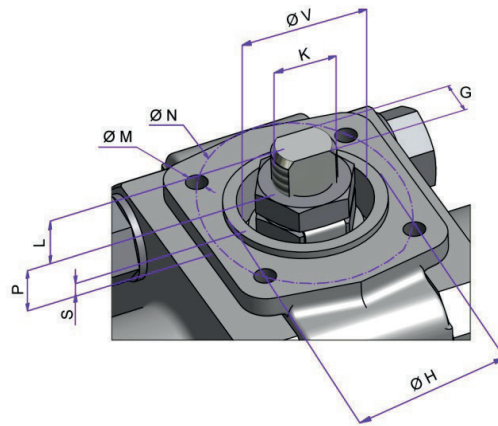

**TOP VIEW**

FULL BORE							TOP MOUNTING														
VALVE SIZE		DIMENSION [mm]					WEIGHT [kg]	DIMENSIONS [mm]											ISO 5211	TORQUE [N.m]	MAST [N.m]
NPS	DN	A	BORE	C	E	F	BW-SW	L	P	S	V	K	G	H	N	M					
1/4" x 1/4"	08 x 08	75	11.1	79	30.5	144	1	3.6	5.4	1.5	21	M10x1	5.5	25	36	M5x8	F03	10	65		
3/8" x 3/8"	10 x 10	75	11.1	79	30.5	144	1	3.6	5.4	1.5	21	M10x1	5.5	25	36	M5x8	F03	10	65		
1/2" x 1/2"	15 x 15	80	14.2	81	32.5	144	1.2	3.6	5.9	1.5	21	M10x1	5.5	25	36	M5x8	F03	14	65		
3/4" x 3/4"	20 x 20	100	20.5	98	39	172.5	2.3	9	5	1.5	25	M12x1.25	7.5	30	42	M5x8	F04	23	100		
1" x 1"	25 x 25	110	25.4	100	38	172.5	3.2	10	10	1.5	25	M12x1.25	7.5	30	42	M5x8	F04	27	100		
1.1/4" x 1.1/4"	32 x 32	120	31.7	110	43.5	218	4.5	13	14	1.5	30	M15x1.5	8.9	35	50	M6x10	F05	32	180		
1.1/2" x 1.1/2"	40 x 40	140	38	112	47.5	218	5.3	14	14	1.5	30	M15x1.5	8.9	35	50	M6x10	F05	37	180		

- Net torque measured with clean water at ambient temperature

- Mast for AISI 316 material

## PRESSURE/TEMPERATURE LIMITATION OF SEAT SEAL (according working conditions)

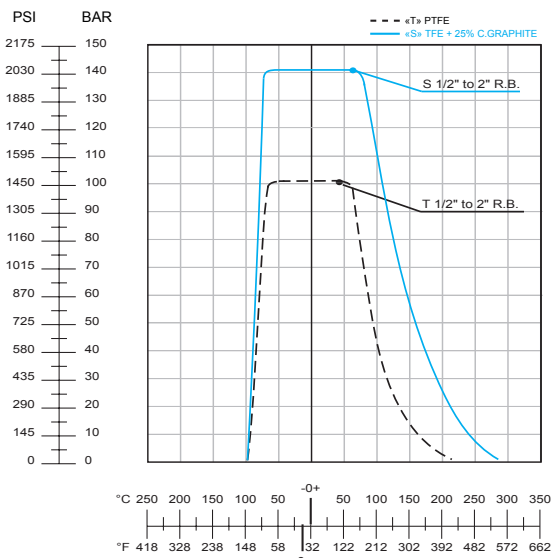

## DIFFERENT CONFIGURATIONS (others on request)

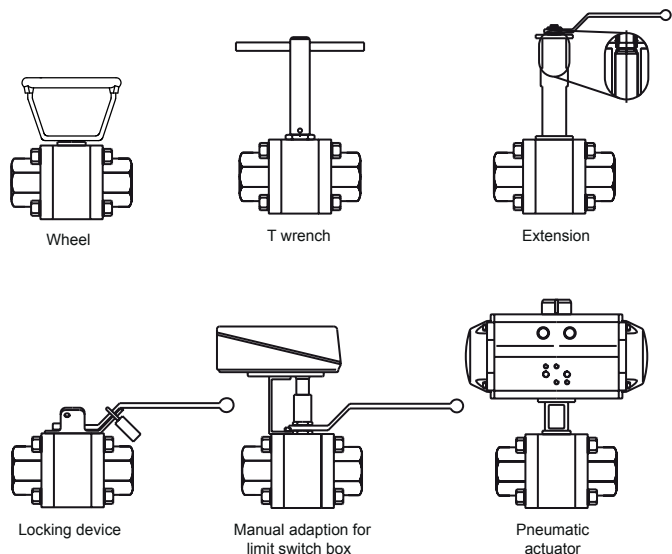

ref n°DS1070 Rev0 (datas not contractual)